

○ Futuro do self-service - Cenário 1

# ○ self-service adequado

STUDIOINO 

# As novas dores dos operadores de self-service

## Riscos de contágio da Covid-19

Cuidados com a higiene pessoal

Aglomeração de pessoas

Consumidores falando enquanto se servem

Risco de contaminação dos alimentos expostos

Compartilhamento de utensílios

Percepção de insegurança dos consumidores



Solução:

Adequação do bufê

Criar barreiras de proteção entre os consumidores, alimentos e pessoal de serviço





Before placing your order, please inform your server if a person in your party has a food allergy.



Hand Si









Hot/Cold Shelves Built-In



PORTABLE PLEXIGLASS SHIELD

VERTICAL FIXED SHIELD

VERTICAL ADJUSTABLE SHIELD



## Cashier Shield

Models: CS3040P, CS3236SP

Hatco's lightweight, clear, transparent Cashier Shield can help you in your effort to prevent the spread of germs and viruses at checkout registers, restaurants, pharmacies and other customer interaction areas. It acts as a physical barrier that can limit the passing of contagions at customer interaction points. Clear partitions are more important than ever. Cashier Shield can stand on it's own and does not require tools for assembly. Feet can be secured to surface using mounting screw holes if desired.

### Standard features

- Helps maintain social distance and physical separation
- Helps protect customers and employees
- Easily sanitized using non-abrasive cleaners
- Completely transparent/clear - will not obscure vision
- More impact resistant than glass
- Durable and light weight
- Rounded edges
- Easy to install
- CS3040P:
  - Convenient pass-through window at base of shield
  - .375" (10 mm) thick sturdy polycarbonate shield
  - 14 gauge Stainless Steel feet with mounting holes provided
- CS3236SP:
  - .227" (5.8 mm) thick Acrylic shield
  - 1" (25 mm) square box Stainless Steel tubing support legs
  - Easy to assemble without tools (simple thumb screws secure shield to legs)
  - Legs have screw holes for secure mounting
  - Shield stands at a 70° angle

Project \_\_\_\_\_

Item # \_\_\_\_\_

Quantity \_\_\_\_\_



# KEEP MY FOOD

Protetores Salivares Conversíveis - NSF

Pratos servidos



# KEEP MY FOOD

Protetores Salivares Conversíveis - NSF

Autosserviço e pratos servidos

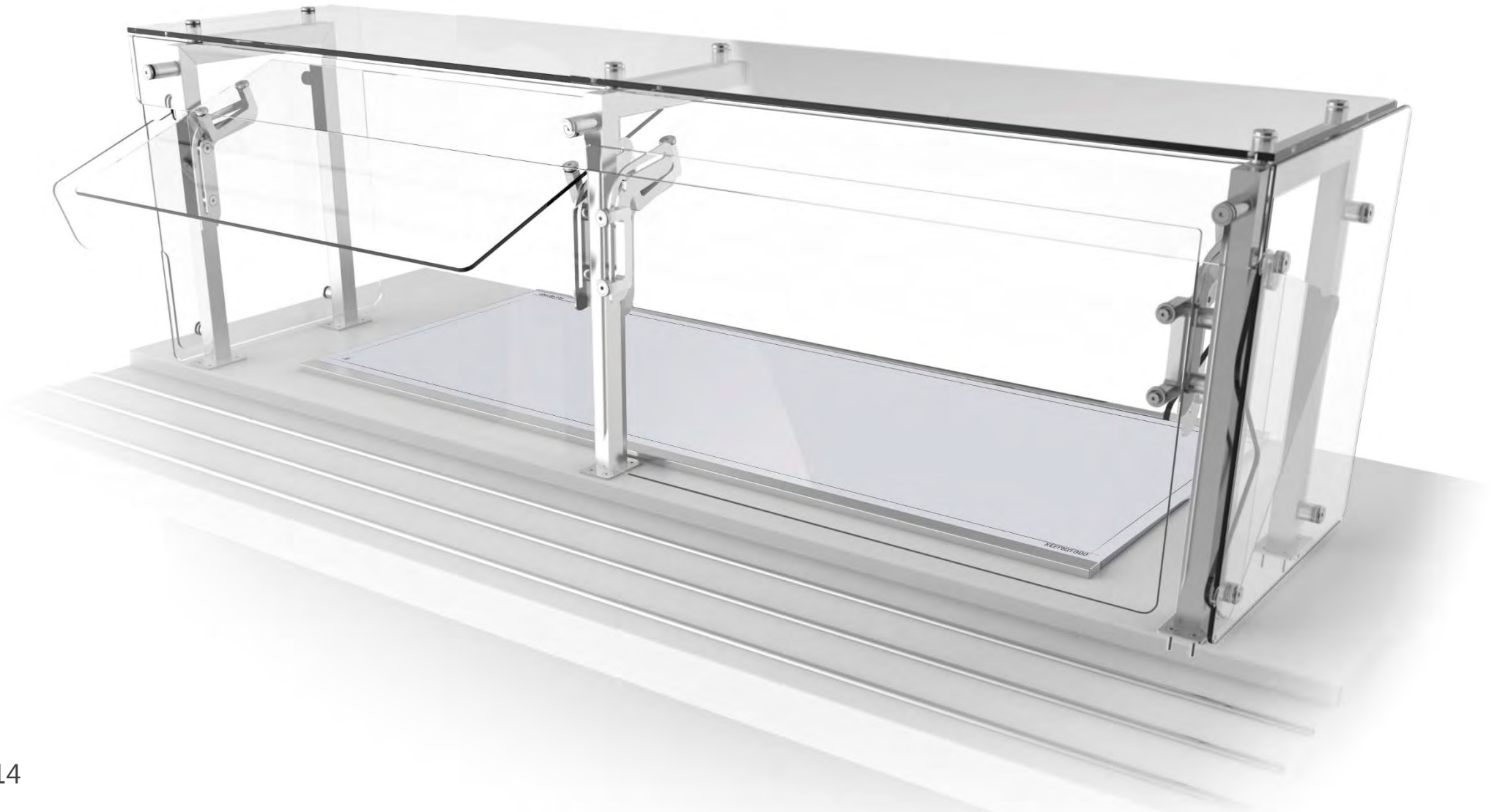

# KEEP MY FOOD

Protetores Salivares Conversíveis - NSF

Autosserviço e pratos servidos

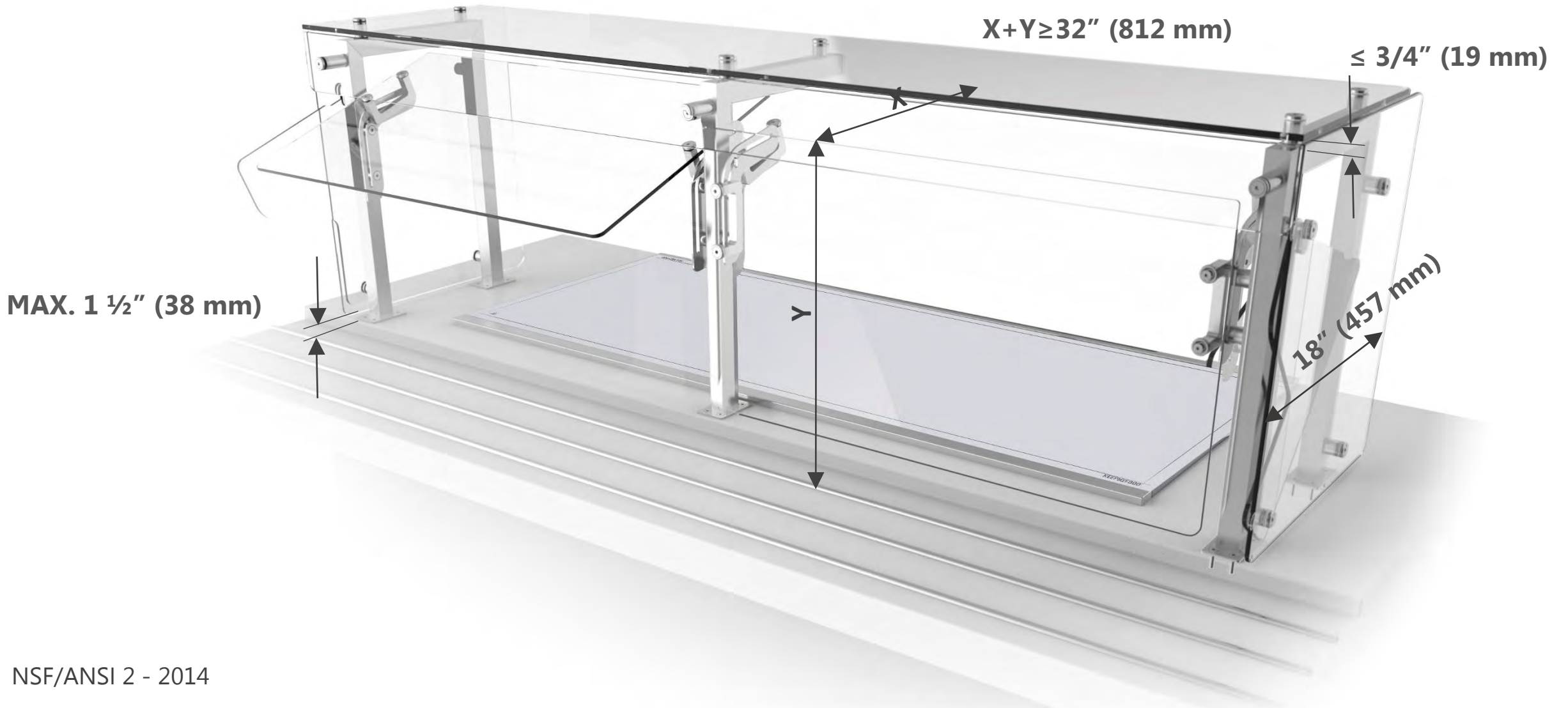



Model HSB  
Includes Spout,  
Basket, Foot Pedals



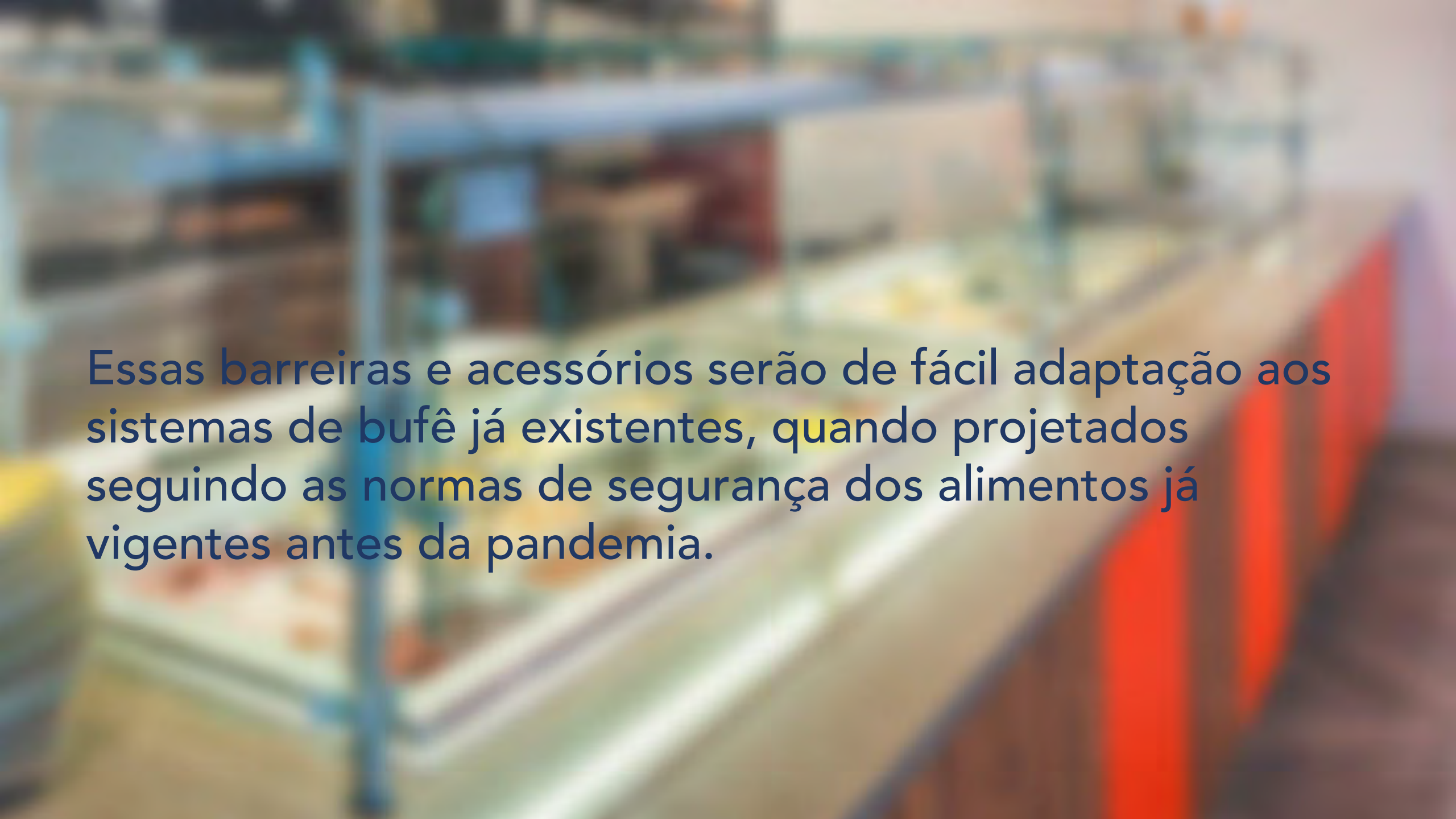

Essas barreiras e acessórios serão de fácil adaptação aos sistemas de bufê já existentes, quando projetados seguindo as normas de segurança dos alimentos já vigentes antes da pandemia.

Então, vamos se preparar para a reaberturas dos self-service!

STUDIOINO 

[www.studioino.com](http://www.studioino.com)

